

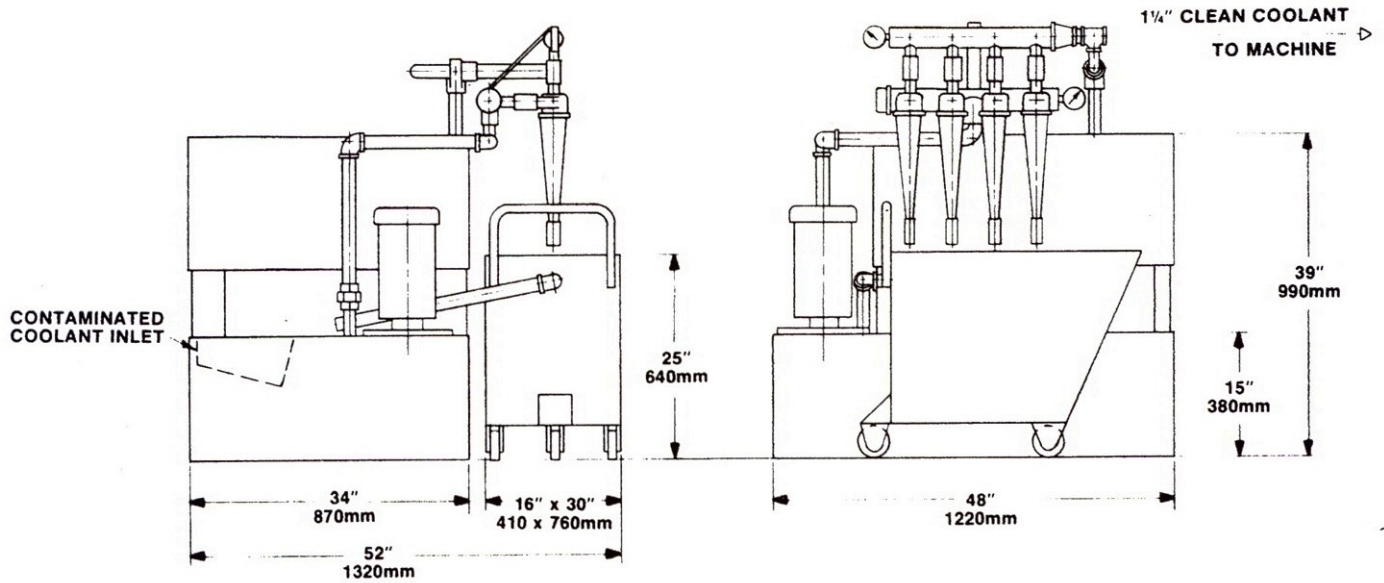

CYCLOTRON PRODUCTS, INC.

Hydrocyclonic Coolant Filtration Systems

150 SERIES



SPECIFICATIONS	CT60-150	CT80-150
Flow Rate Gallons per Minute	60	80
Tank Capacity Gallons	150	150
Swarf Cart Gallons	35	35
Inlet Height Inches/mm	15/380	15/380
Cyclone Pump Horsepower	3	3
Number of Cyclones in System	3	4

COMPONENT SPECIFICATIONS

Piping: All piping schedule 40 black iron.

Sheet Metal: 11Ga. hot rolled steel.

Painting: Two part epoxy primer and finish coat, any color specified.

Screened Inlet: Perforated steel, 1/8" diameter holes.

Relief Valve: Stainless steel piston, cast iron housing.

Gages: Inlet 0-60 PSI, outlet 0-30 PSI.

Cyclone Pump: Cast iron with centrifugal impeller.

Electric Motors: TEFC for 230/460/3/60 Hz. operation.

OPTIONAL:

Electrical Controls: NEMA 12 enclosure with AC manual starter, start and stop push buttons.

Clean Coolant Pump: Rated flow up to 25 PSI.

Special systems designed to specifications.

Specifications are subject to change without prior notice.